

HIGH TEC

Geben Sie hier den
Modellnamen ein

1329-316-02

Geben Sie hier die
Modellnummer ein

316

Geben Sie hier
den Typ ein

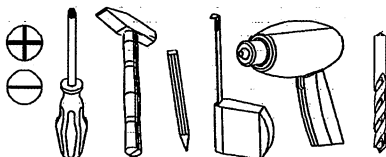
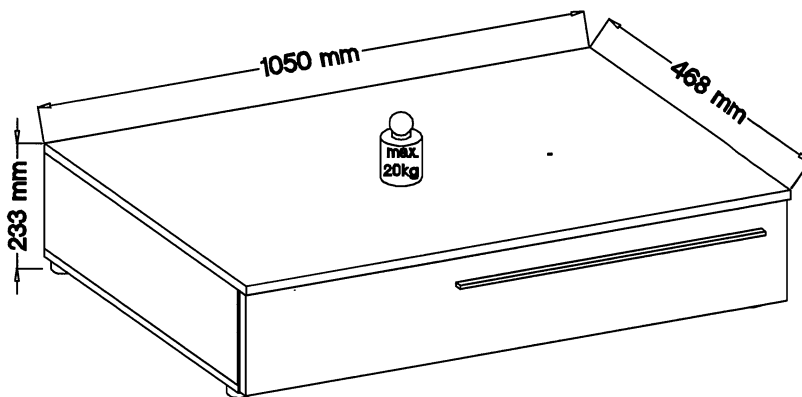
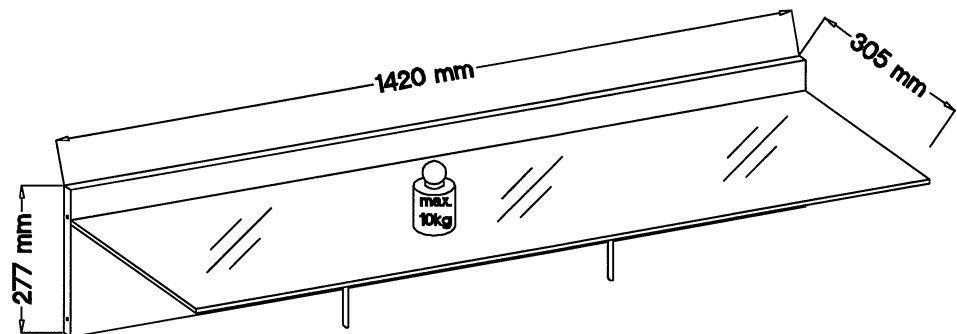
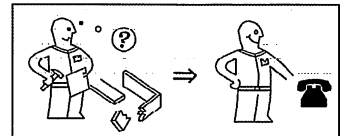
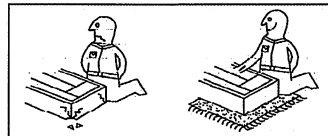
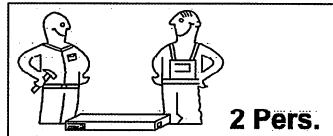

festziehen / tighten / Затягивать / serrar / stringere / utáhnout / vasttrekken / zategnuti / strángere / zvlazac / zacisnac / szorosan meghúzni / pevne dotáhnut / trdno prilegniti / затянуть / dra át / fíjar / Sıkın



eindrücken / press in / enfoncer / wolsnac / ribattere / zallačit / Вкапайте / indrukken / benyomni / stlačit / vtisniti / tryck in / introduce prin apă sare / вдавить / empujar / çeri bastırın



ausmessen / measure / mesurer / msurare / opmelen / izmeriti / milara / kimérni / izmeriti / măsurare / измерить / změřit / Измерете / mät upp / zmierzyc / medir / Ölçün



drücken / press / presser / stisknout / Натиснете / vtisniti / nasnac / drücken / pritisnuti / nacisnac / pritisniti / нажать / (meg)nyomni / apasare / tryck fast / nacisnac / presionar / Bastırın



einschlagen / hammer in / beverni / sla in / frapper au marteau / infossare / Zabit' / zarazit / Набейте / zabiti / wbic' / introduce prin bătăle / забить / zallout / çavar / çeri vurun



Drehen - wenden / przekręcić - odwrócić / Keren - omdraalen / Girare - Ruotare / Okrenuti - ubrnuti / Retourner - renverser / Turn over - turn around / Otočte - obratite / Заверте - обьрните / Obmíte list / Intoarceți - roții / Vrát runt - vänd / прокрутить - повернуть / otocit - obrátit / elforgatani - megfordítani / Girar / Çevirin

HIGH TEC

**Geben Sie hier den
Modellnamen ein**

1329-316-02

**Geben Sie hier die
Modellnummer ein**

316

**Geben Sie hier
den Typ ein**

D Unser Direktservice für Beschlagteile
Sollte Ihnen ein Beschlagteil fehlen, können Sie dieses Servicekort direkt an die untenstehende Adresse mailen. Wir können allerdings nur Beschlagteile auf diesem Wege verschicken. Sollten Sie eine andere Beanstandung an Ihrem Möbelstück haben, so wenden Sie sich bitte direkt an Ihr Möbelhaus.

GB Our direct order service for fitting
If a fitting part is missing, you can e-mail this service card directly to the address below. However, we can only send fitting parts in this way. If you have any other cause for complaint concerning your item of furniture, please contact your furniture store directly.

CZ Naše přímé služby pro kování
Chybí-li vám nějaký díl z kování, můžete tuto servisní kartu odeslat e-mailem přímo na níže uvedenou adresu. Tuto cestou však můžeme zosadit jen díly kování. Pokud byste reklamovali jiný díl nábytku, obraťte se přímo na svého prodejce nábytku.

F Bien étudier la notice de montage
S'il vous manque une ferrure, veuillez envoyer directement la présente carte service à l'adresse e-mail indiquée ci-dessous. Cependant, ceci nous permet uniquement d'envoyer des ferrures. Pour tout autre type de réclamation concernant votre meuble, veuillez contacter directement votre magasin d'ameublement.

I Il nostro servizio diretto per il ordine della ferramenta
Qualora Vi dovesse mancare un pezzo di fissaggio, allora Vi preghiamo di inviare questa carta di servizio immediatamente all'indirizzo sottostante. Possiamo inviare i pezzi di fissaggio solamente per mezzo di questo procedimento. Qualora dovete avere qualche altra reclamazione in merito al mobile, allora Vi preghiamo di rivolgerVi direttamente al Vostro Negozio di mobili.

BG Ако липсва част от комплекта, попълнете настоящата сервисна карта и ни я изпратете на e-mail адреса, посочен по-долу. По този начин можем да доставим само пилватични елементи от обкова. Ако установите други дефекти по мебелите, Ви съветваме да се обърнете към мебелната къща/магазин, от който сте закупили стоката.

NL Onze directservice voor losse onderdelen
Wanneer er een onderdeel ontbreekt, kunt u deze servicekaart direct aan ons sturen. Wij kunnen langzame deze weg echter alleen beslagdelen versturen. Mocht u een ander probleem aan uw meubel hebben, verzoekten wij u contact op te nemen met uw meubeldealer.

PL Nasz bezpośredni serwis części montażowych
Jeżeli brakuje części koniecznych do montażu, prosimy o przesłanie nam niniejszej karty serwisowej na niżej podany adres e-mailowy. W ten sposób możemy przesłać Państwu tylko brakujące części. W przypadku innych reklamacji dotyczących mebli, prosimy zgłosić się do salonu meblowego, w którym został dokonany zakup.

HR Servis za okovicu
U slučaju da nedostaje neki od dijelova molimo vas da na dolje navedenu mail adresu pošaljete ovaj servisni obrazac. Na ovaj način mogu se dostaviti samo okovicu. U slučaju da imate dodatne prigovore vezane uz komad namještaja molimo vas da se obratite izravno trgovini namještaja gdje je isti kupljen.

HU Direktkezelésünk vasaltnok esetén
Ha hiányzik egy vasalat, ezt a kártyát közvetlenül elküldheti az alább található címre. Azonban csak a vasalatosok tudunk így küldeni. Amennyiben másfajta reklamációt állt fenn birtokdarabját illetően, forduljon közvetlenül a bolti üzletnek.

SK Naš priamy servis pre časti kovania
Ak by vám chýbala nejaká časť kovania, môžete poslať túto servisnú kartu pošťou e-mailom na nižšie uvedenú adresu. Diely kovania vieme poslať iba týmto spôsobom. Ak by ste mali inú reklamáciu ohľadom Vašho nábytku, obráťte sa priamo na Vašu predajňu nábytku.

SLO Naše direktno uslužbno storitve za okovicu
Če vam manjka kakšno okovicu, lahko to servisno kartico pošljete po e-pošti direktno na spodnji naslov. Po tej poti vam lahko pošljemo samo okovicu. Če želite reklamirati kakšen drug del pohištva, se obrnite neposredno na vaso trgovino pohištva.

RO Serviciu-ul nostru direct pentru feronerie
In cazul in care va lipsesc o piesa de feronerie puteti sa trimiti direct acest card de service prin e-mail la adresa de mai jos. Noi nu putem expedia piese de feronerie decat pe aceasta cale. Daca aveți o alta reclamație referitoare la piesa de mobilier, atunci va rugăm să vă adresați direct la magazinul dvs. de mobilier.

RUS Наш прямой сервис для поставок фурнитуры
Если окажется, что Вам не хватает того или иного элемента фурнитуры, Вы можете отправить сервисную карту по факсу непосредственно на нижеуказанный адрес электронной почты. Однако, таким образом мы можем переслать лишь фурнитуру. Если же у Вас возникнут иные претензии относительно приобретенной мебели, пожалуйста, обращайтесь непосредственно в организацию, осуществлявшую продажу.

S Vår direktservice för beslagsdelar
Om du saknar en beslagsdel kan du skicka detta servicekort direkt till e-postadressen som anges nedan. Tank på att detta är den enda möjligheten att skicka beslagsdelar till dig. Om du vill reklamera din möbel av en annan anledning måste du kontakta ditt möbelhus direkt.

ES Nuestro servicio directo para accesorios
Si le falta algún accesorio, puede enviar esta tarjeta de servicio directamente a la siguiente dirección. No obstante, por este método solo podemos enviar accesorios. Si tiene alguna otra objeción sobre su mueble, consulte directamente con su mueblería.

TR Donatılar için doğrudan servisimiz
Bir donatınız eksikse bu servis kartını doğrudan aşağıda bulunan adrese doğrudan mail yazabilirsiniz. Sadece bu yolla donatılar gönderiliriz. Mobilyanızda başka şikayetleriniz varsa lütfen doğrudan mobilya satıcınıza danışın.

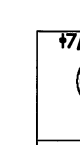
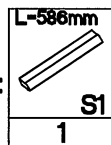
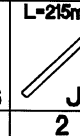
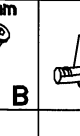
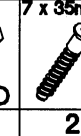
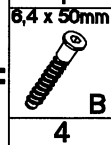
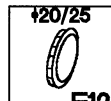
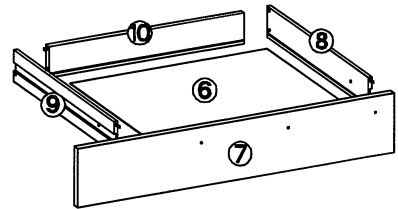
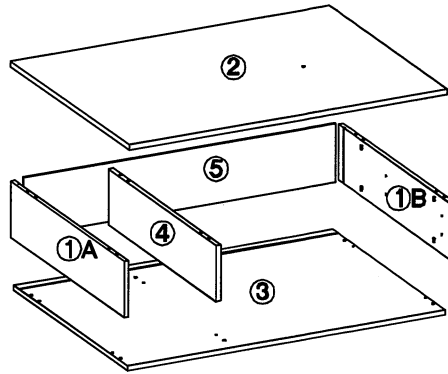
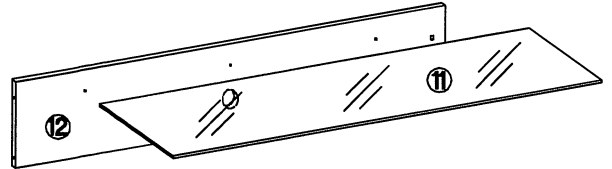

LKZ 80106

Grund der Beanstandung / Reason of the objection:

Möbelhaus / Furniture store:

Name / Name: Telefon / Telephone:

PLZ / postal code: Ort / City:



Strasse / Street:

Haus-Nr. / House No.:

@E-Mail:

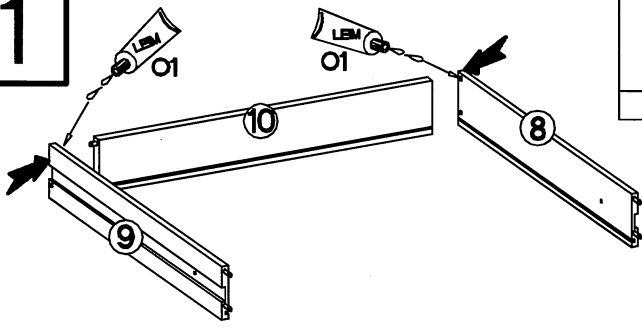
1





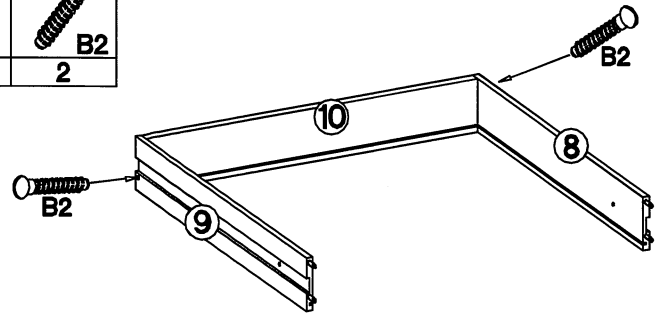

 O1	 B2
1	2

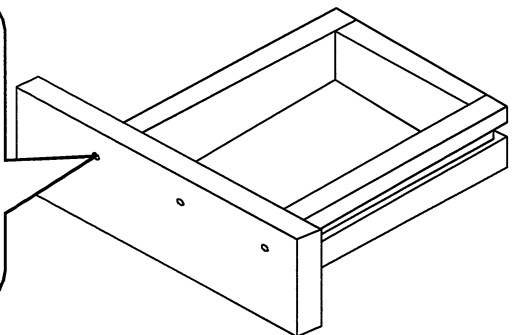
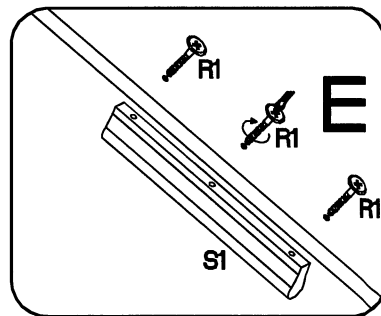
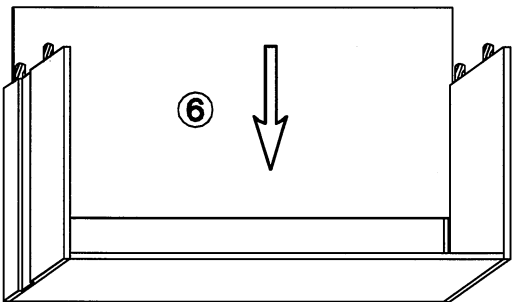
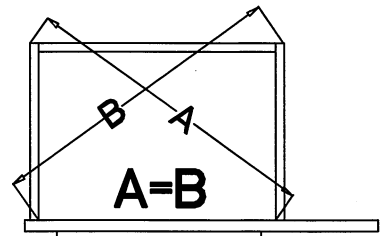
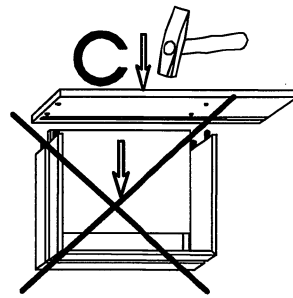
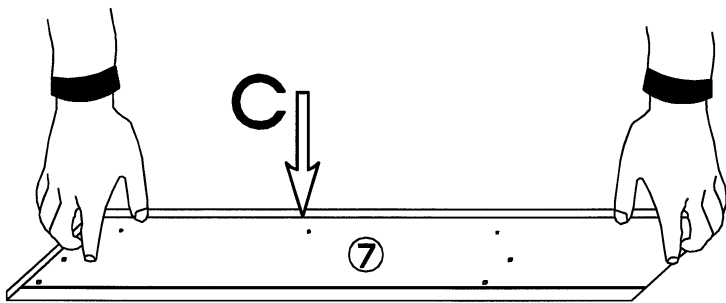
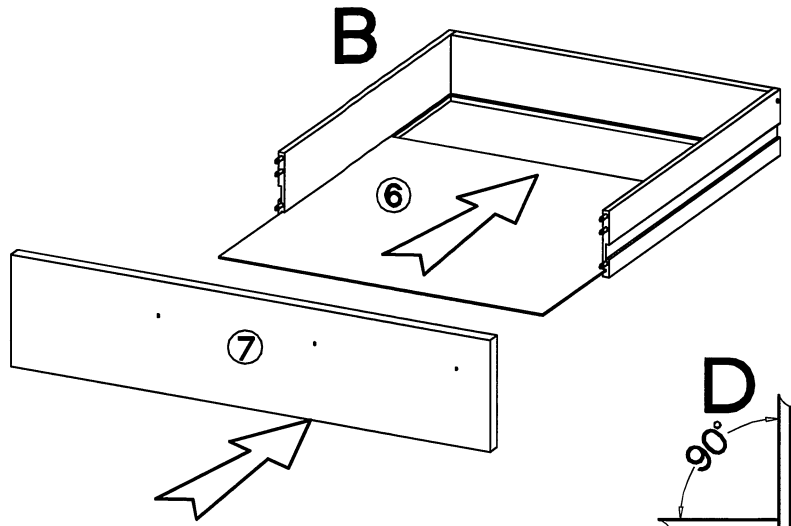
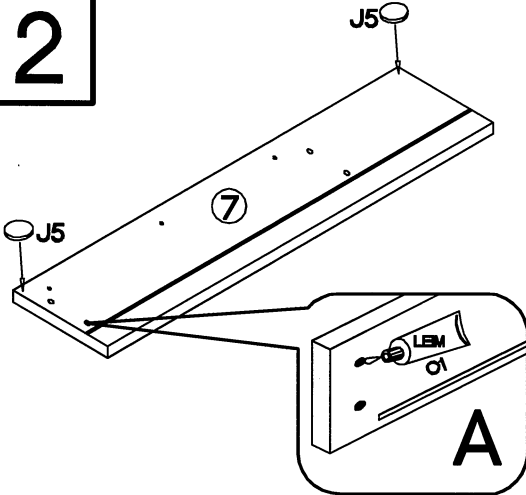





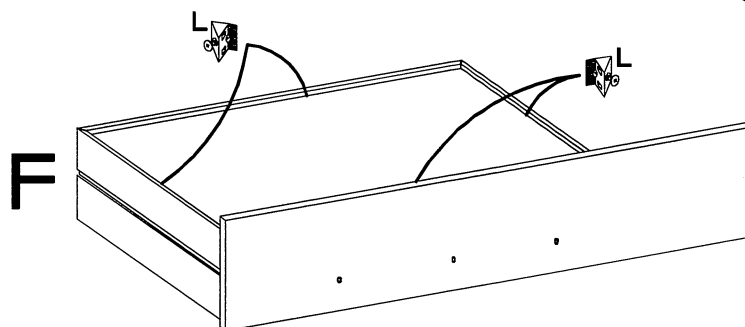

2



 J5	 O1
2	1
 S1	 R1
1	3
 L	
	4



3

 L-20mm D2	 15/12mm C	 16x30mm A	 4.0x25mm P14	 4.0x25mm F10	 6.3x13mm M2	 27/30mm I4
12	12	12	5	5	4	1

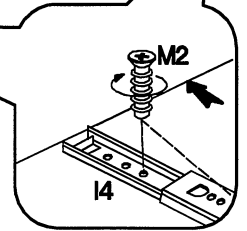
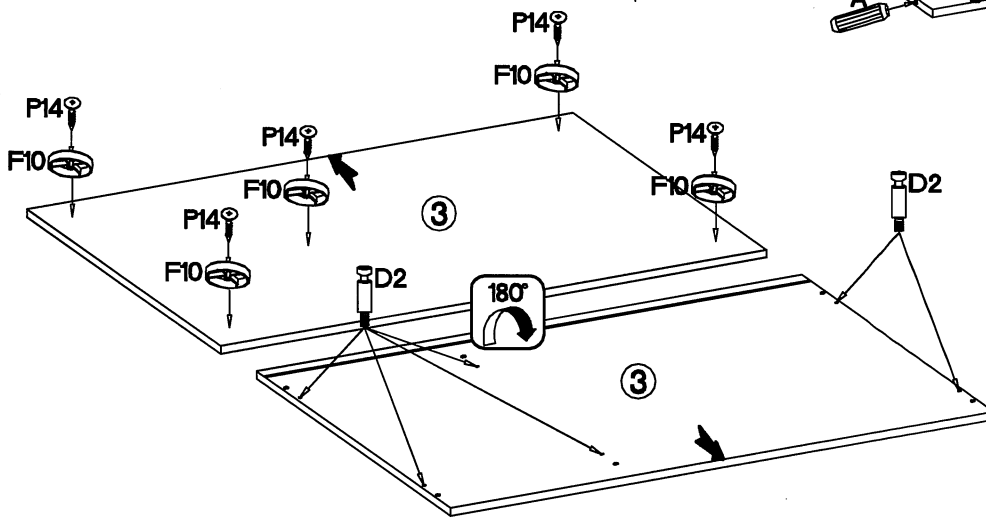
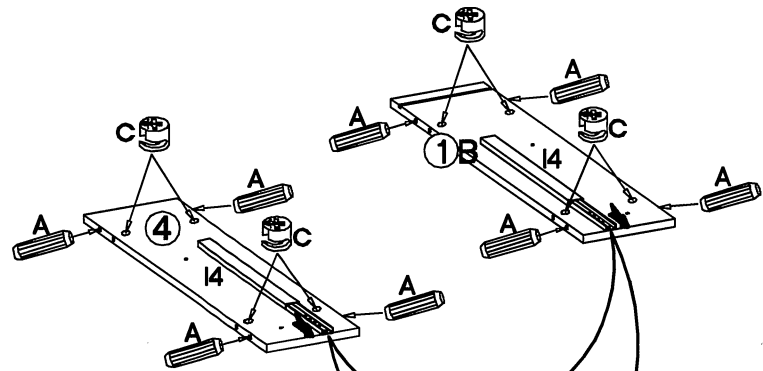
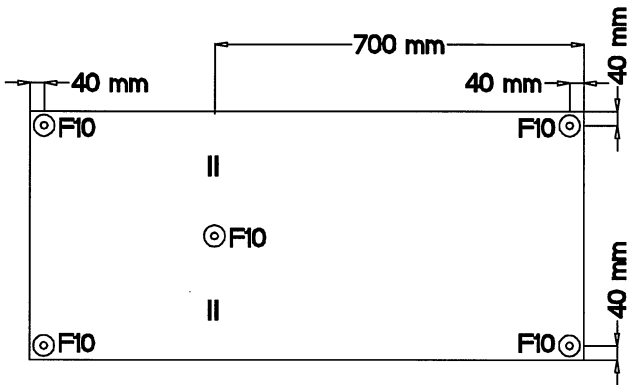
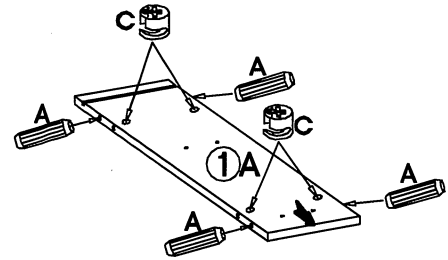
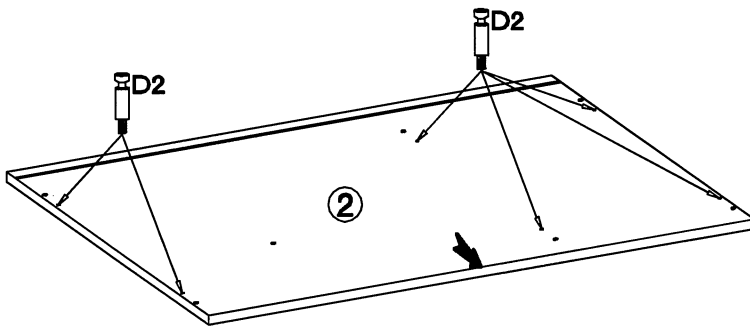
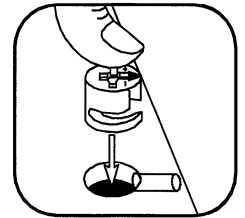
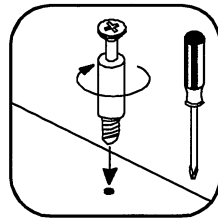

4

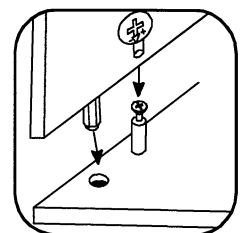
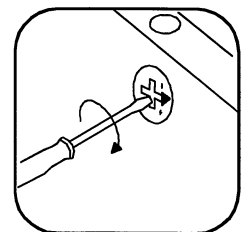
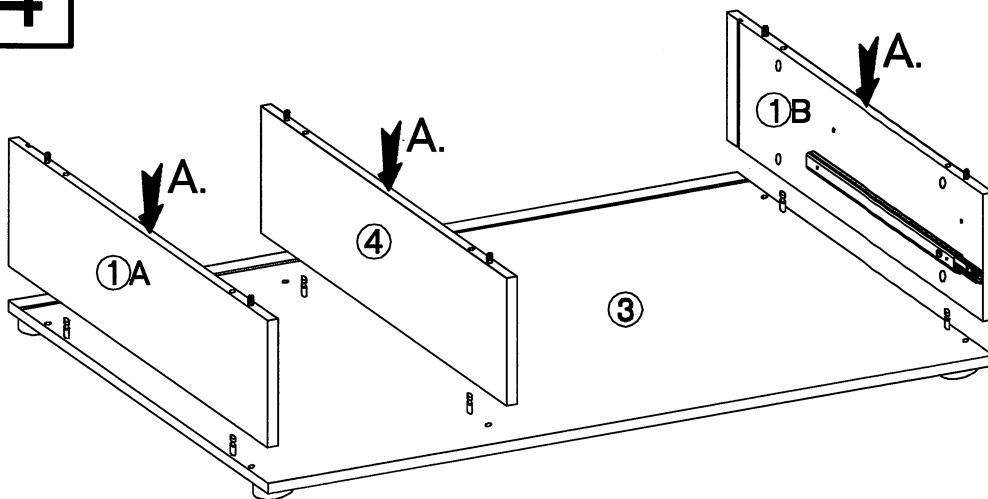

5

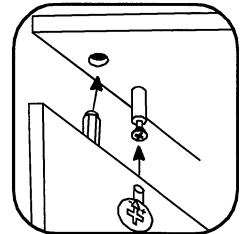
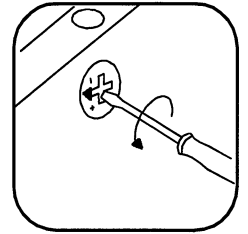
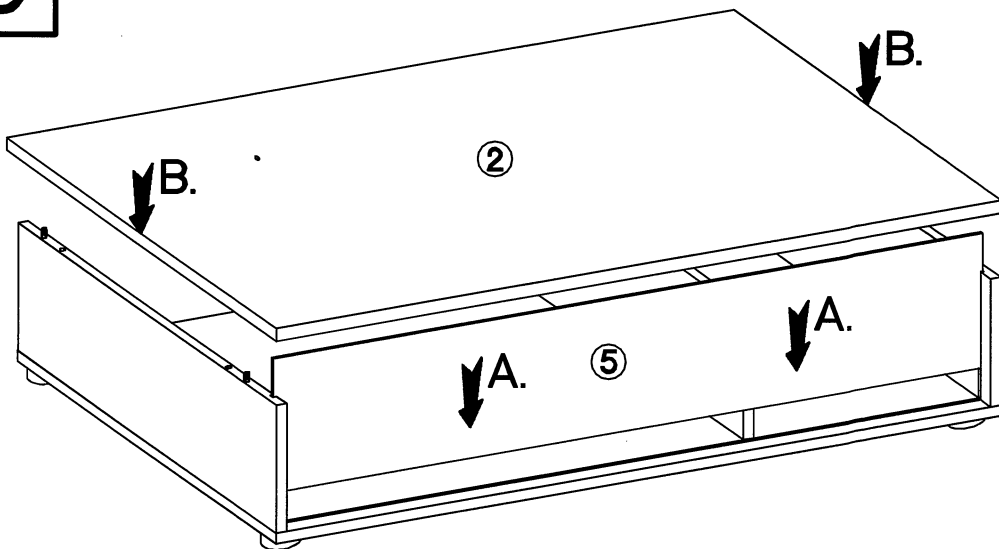

6

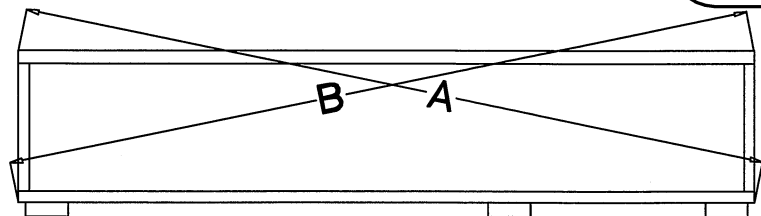
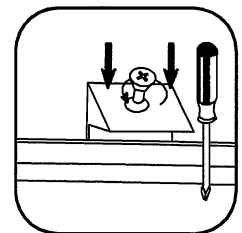
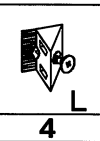
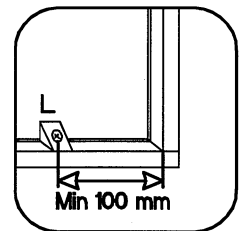
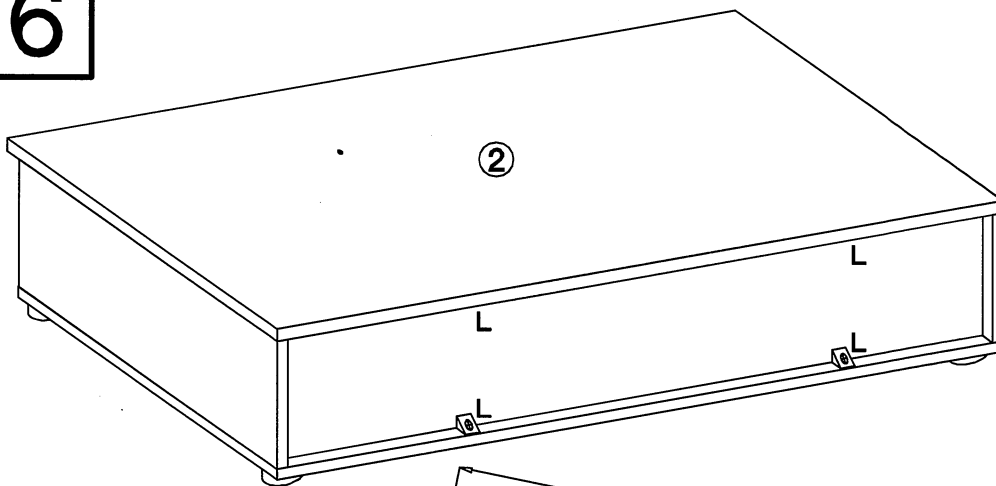

7

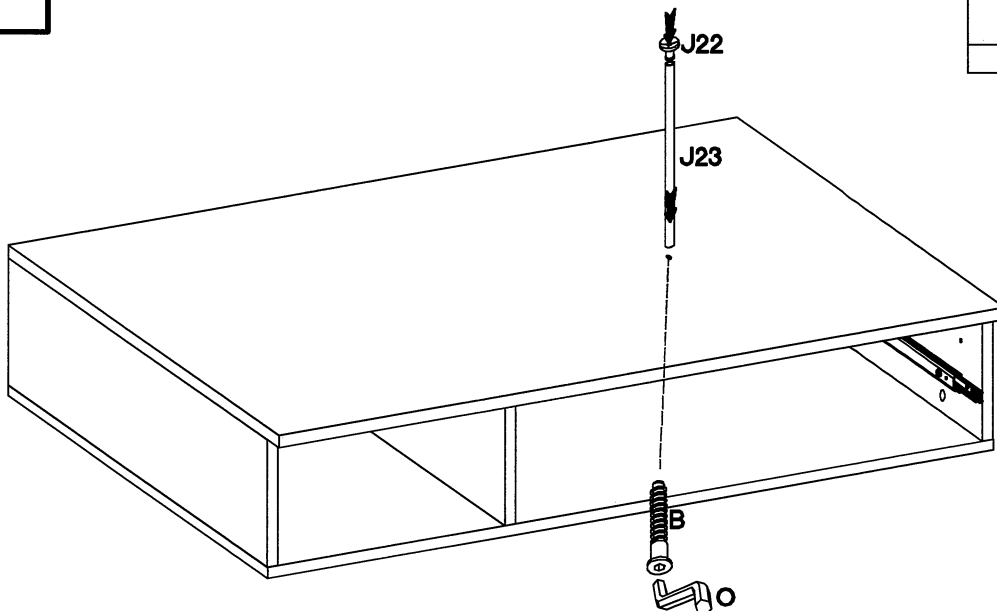

	L=215mm 		7 x 35mm
J22	J23	O	B
1	1	1	1

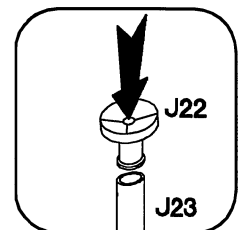

8

M4x9mm



U1

2

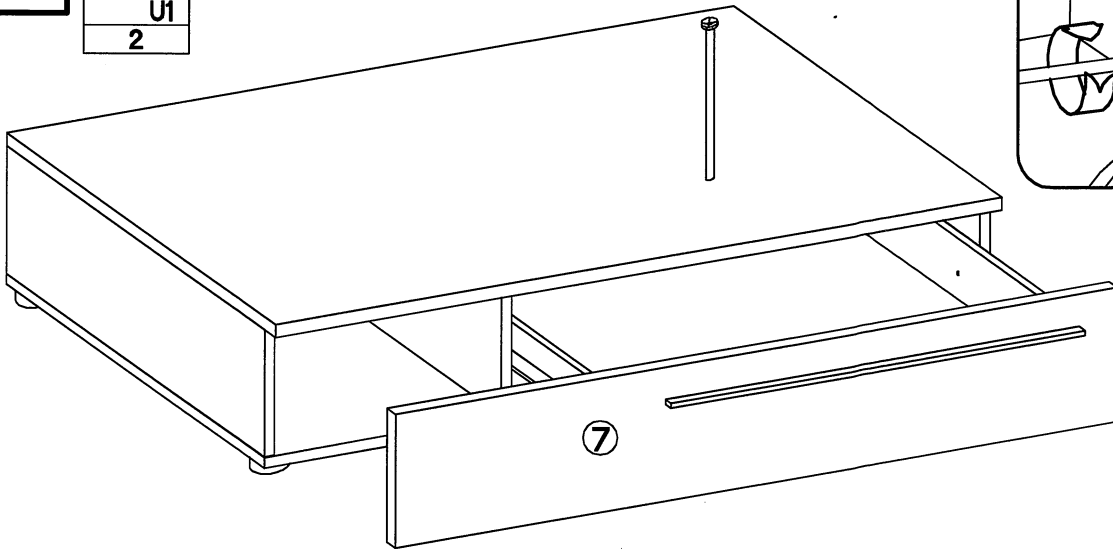
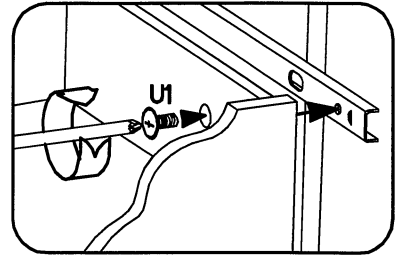

9

∅20/25



E12

1



J21

3

∅60



E8

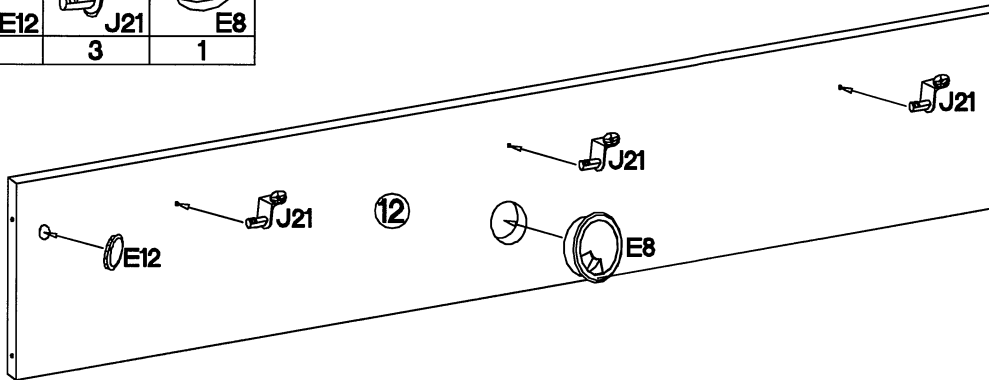

1

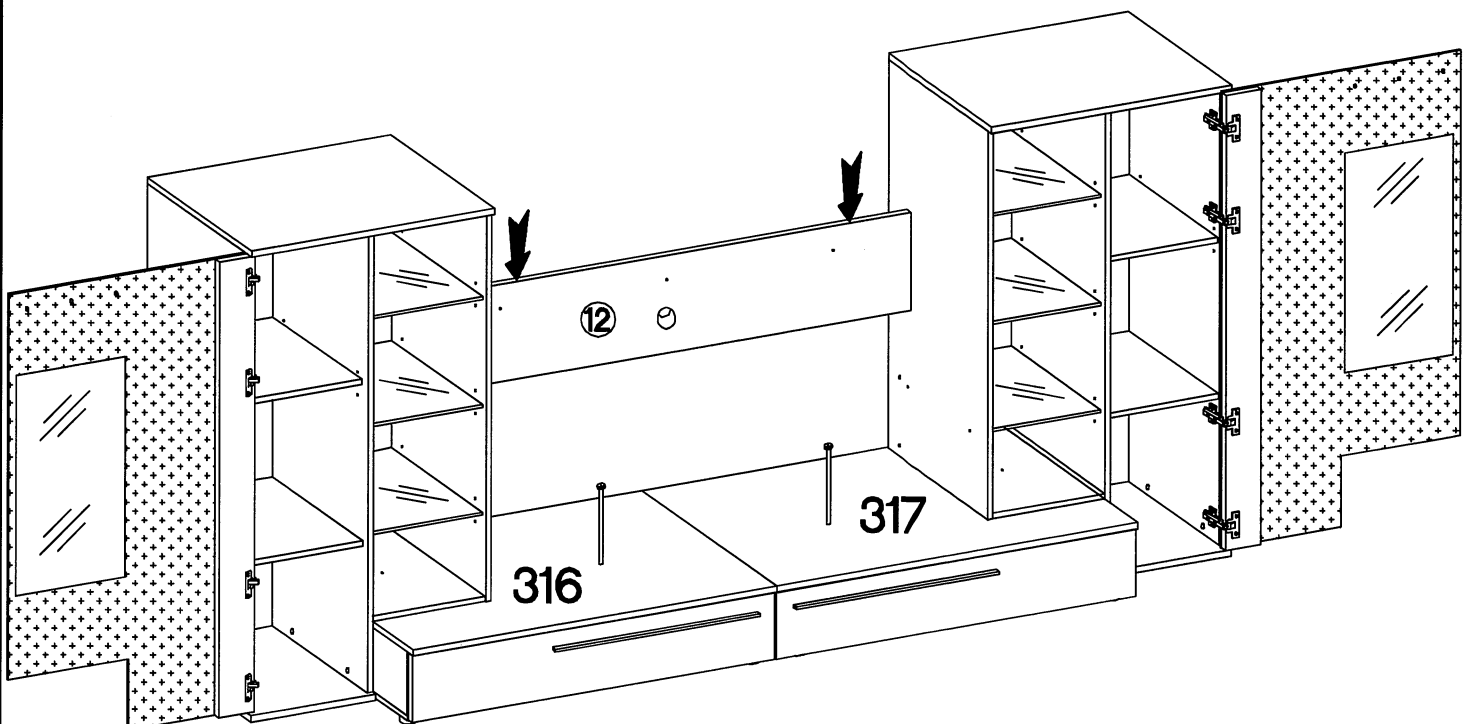

10



11

	6,4 x 50mm		
E1		B	J21
4	4	1	4

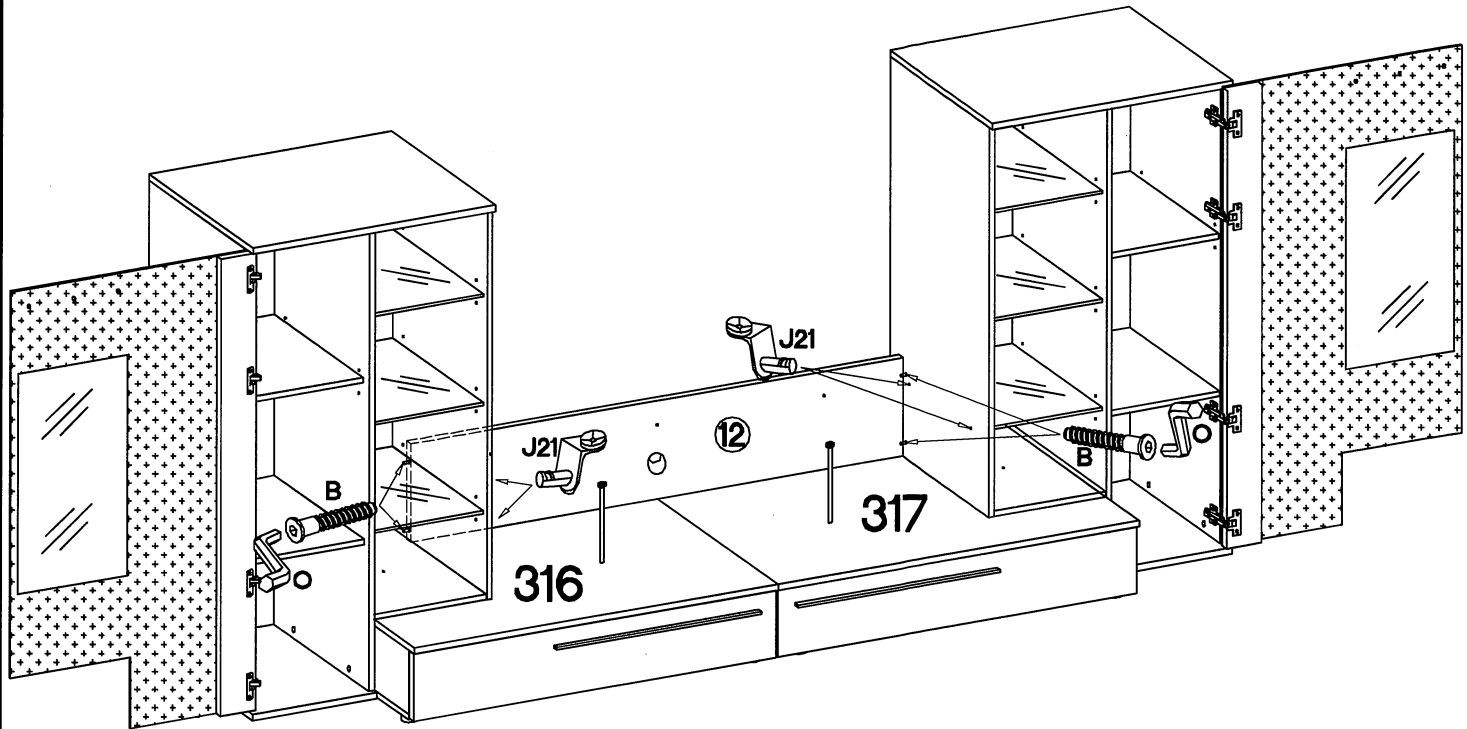

12

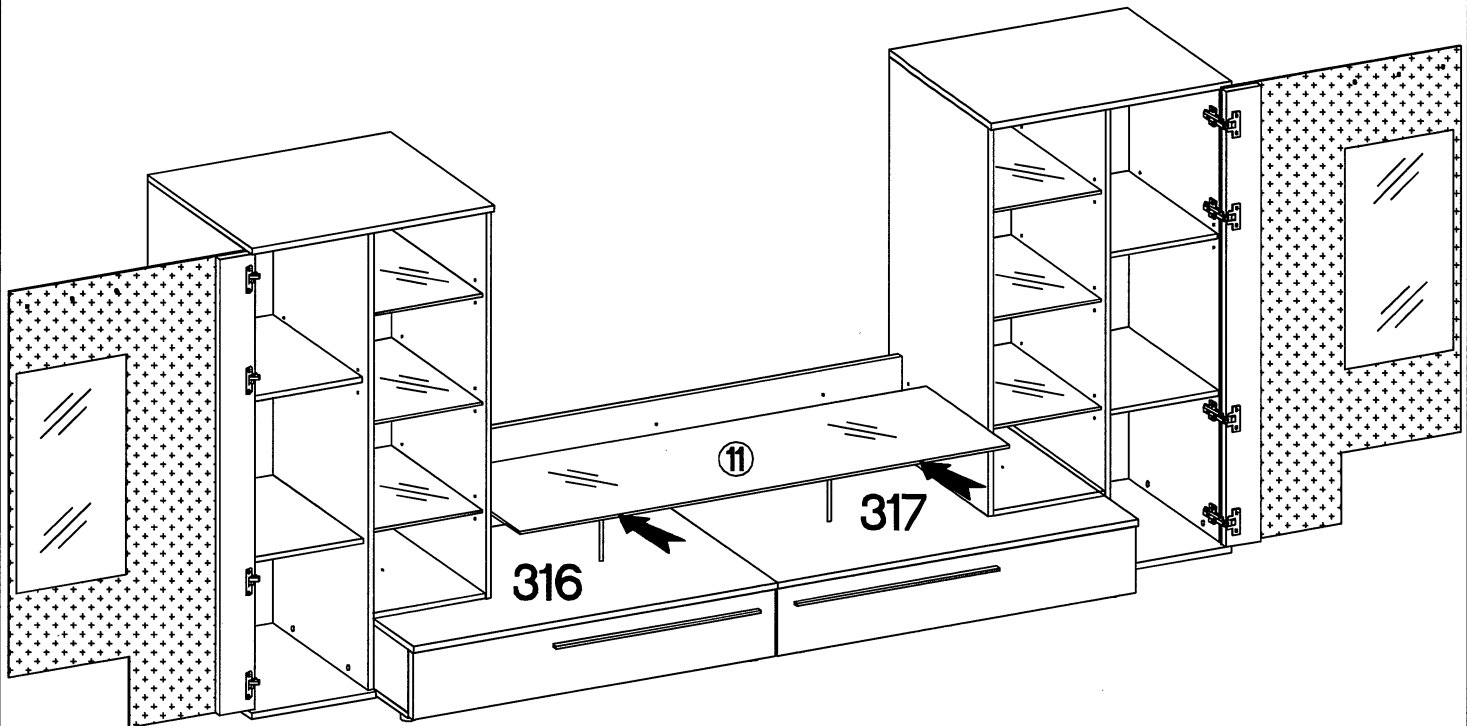

1586,0 mm

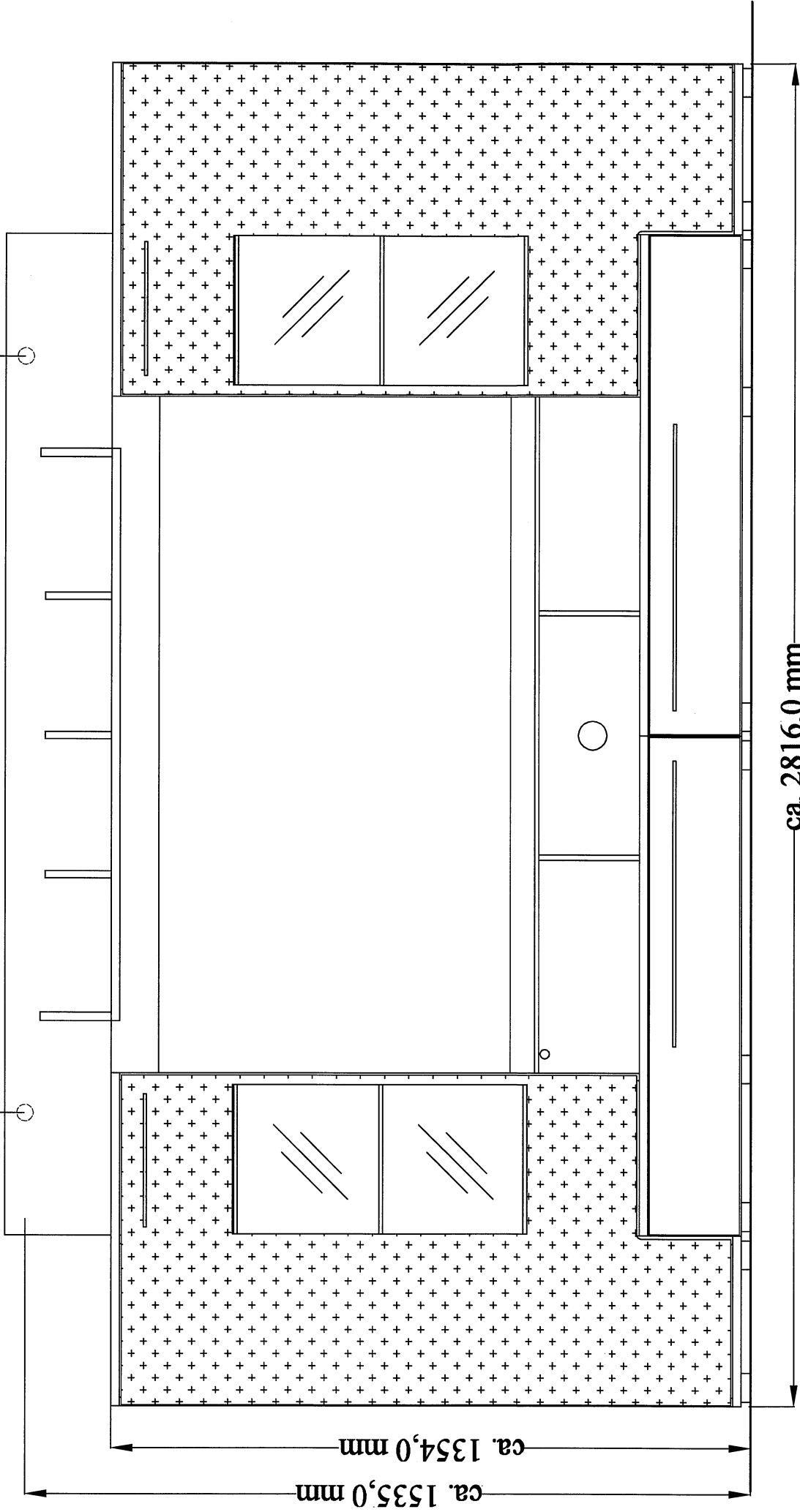

ca. 1535,0 mm

ca. 1354,0 mm

ca. 2816,0 mm

ABW 1329.975.xx

KOMBI SPIGELN