

40min

T	E	4 X 13	Z	G	C	D	H
x 16	x 18	x 2	x 1	x 8	x 8	x 1	

M	K1	4 X 25	B	X	R	U	K	3 X 20	P
x 2	x 4	x 15	x 4	x 15	x 15	x 4	x 12		

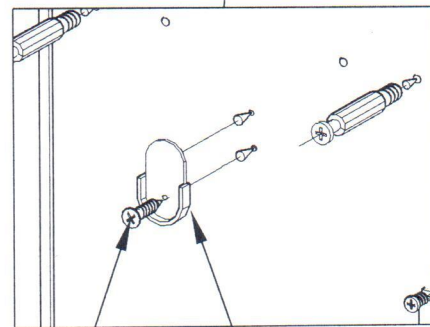
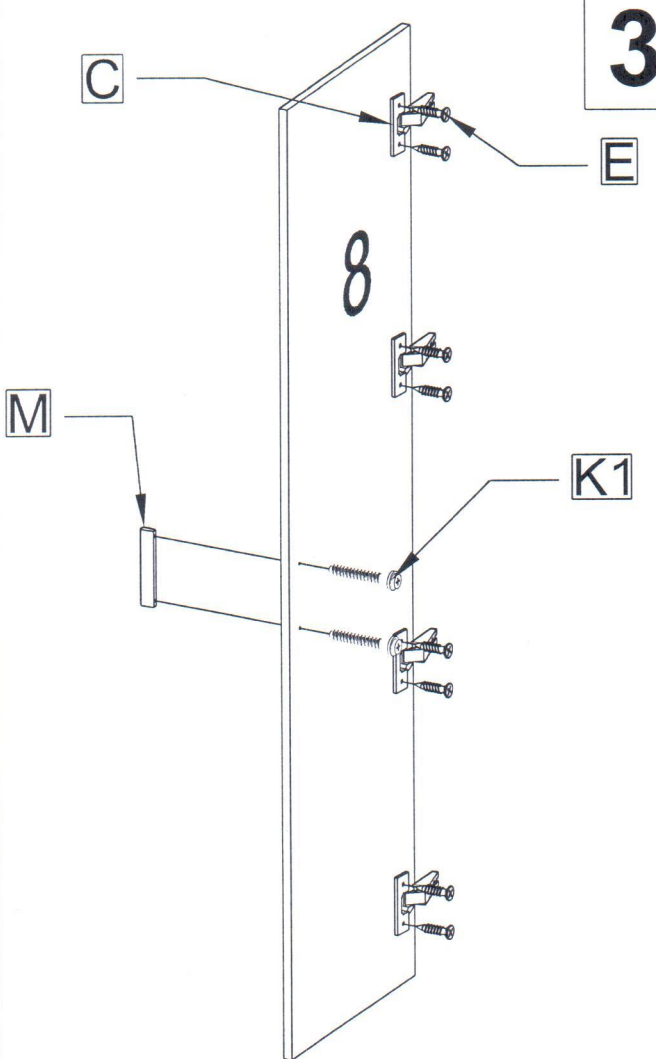
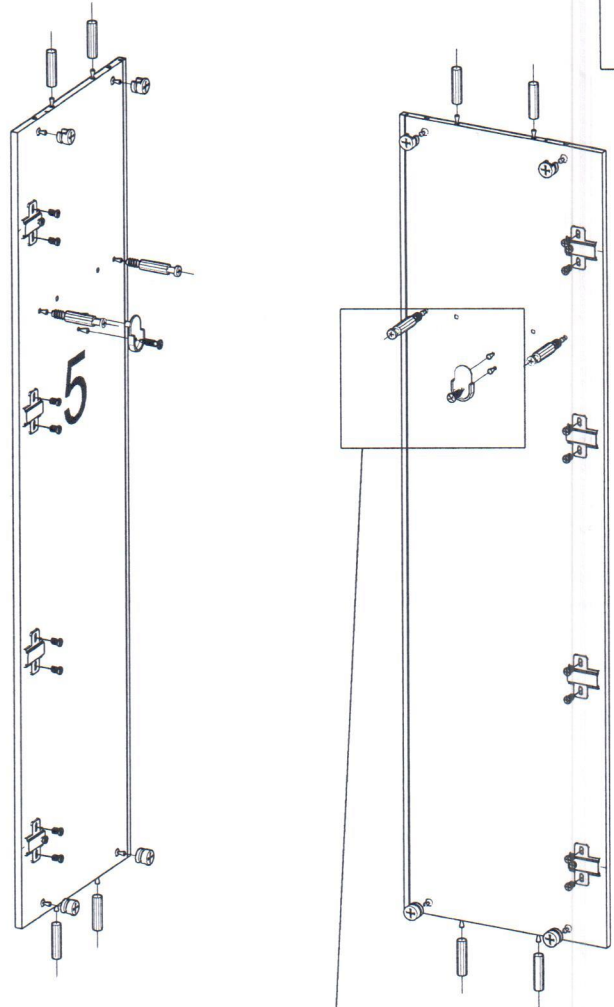
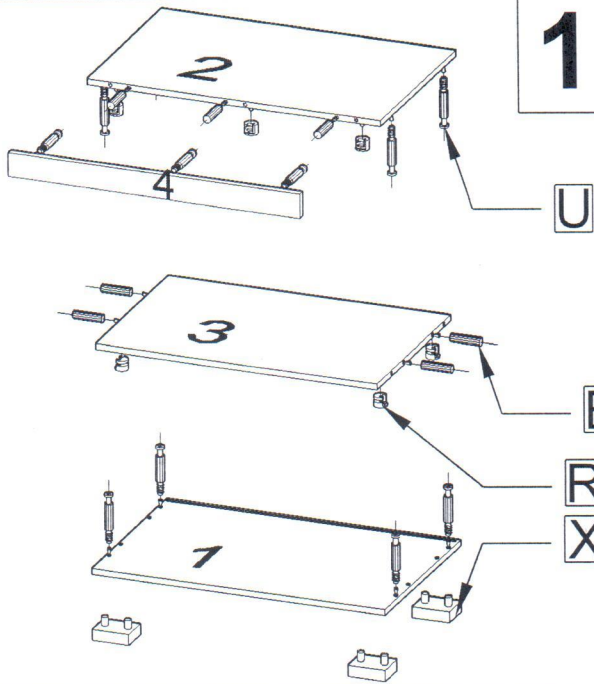

5

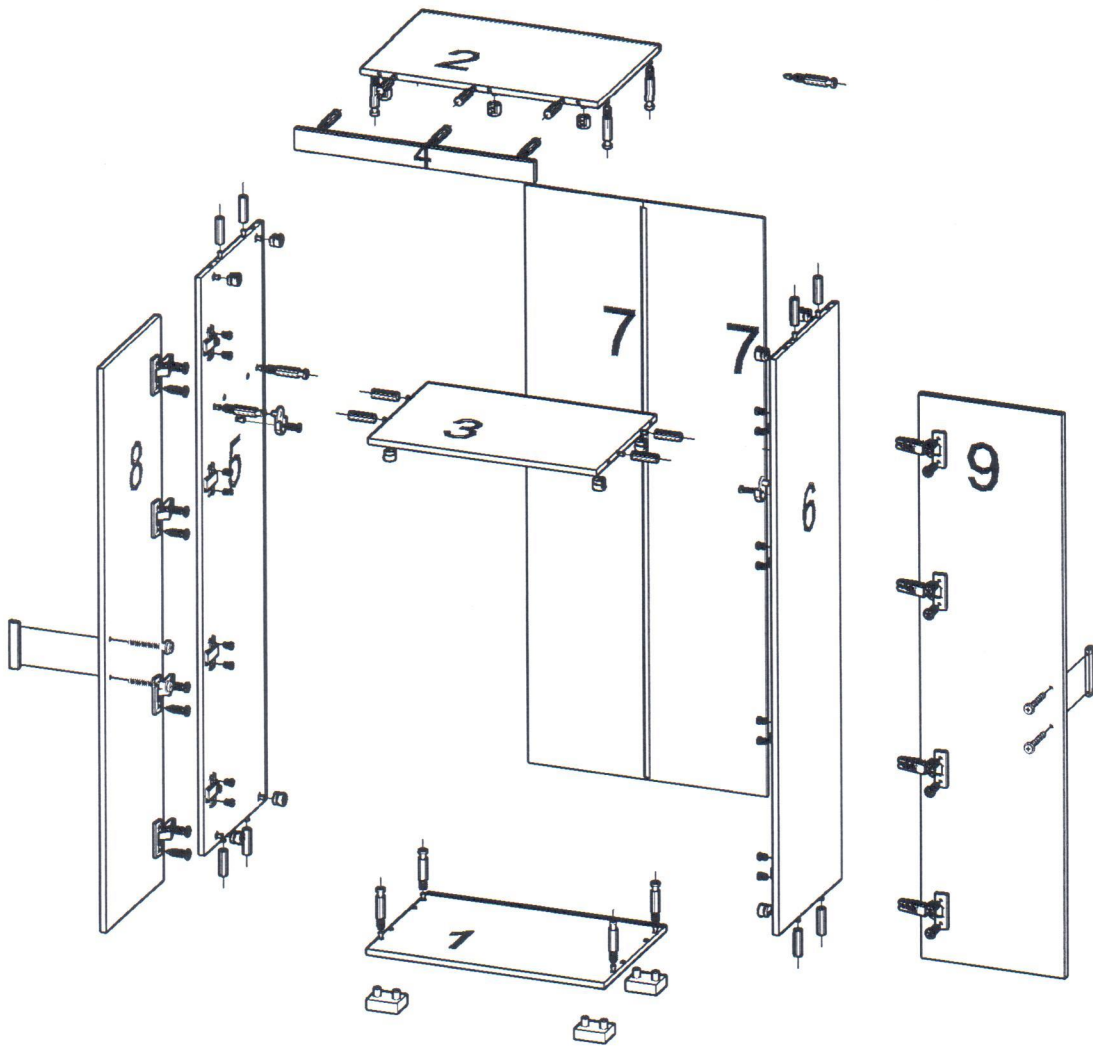

6

